

P14 BR Mk1 PULLMAN BAR SECOND CAR

1 built 1960; withdrawn 1981 and preserved

64'6"

These etched sides can be built into a complete coach using products from our range as supplied in our full kits. Please refer to the panel opposite. They can also be used as a basis for a scratchbuilt coach, or to overlay a suitable ready to run model.

Due to long term contracts with the Pullman Company the British Transport Commission were obliged to run Pullman coaches until 1962. It was considered that there was economic justification to build new stock even though the 1928 stock was still in sound mechanical condition. An order was placed for 44 coaches and in 1960 the Mk1 Pullmans were introduced. All were allocated to the East Coast Main Line for *The Queen of Scots*, *The Master Cutler*, *Tees-Tyne Pullman* and the *Yorkshire Pullman*. As there were no brake ended coaches in the build the 1928 parlour brake thirds were retained until 1965 when BR Mk1 58' Full Brakes replaced them (Comet P4 and B10 respectively). They went on to provide the stock for *The Hull Pullman*, *The White Rose*, *The Talisman* and *The Harrogate Sunday Pullman*. The last BR services worked by these coaches were in May 1978 on the *Yorkshire Pullman* and *The Hull Pullman*.

The Bar Second entered service on the *Tees-Tyne Pullman* as *The Hadrian Bar*, maintaining a tradition established in 1948. In 1970, it was transferred to the LMR.

Running number

Built by Metropolitan Cammell.

354

Livery

As new it had a simple Pullman style livery in umber and cream with the lower panel lined out in buff. It carried 'Pullman' above the windows with the coat of arms at each end and the name or number in a panel at the centre of the coach below the windows. The roof was white, but only for a short while.

In 1970 it was re-liveried in corporate blue/grey, and re-named *The Nightcap Bar* at the left hand end in white letters. A full red band was applied at the cantrail.

Further information

British Railways Mk1 Coaches
BR Mark1 & Mark 2 Coaching Stock

Keith Parkin
Hugh Longworth

Pendragon
OPC

Acknowledgements

Our thanks to Rodney Cooper of Rocar and to the North York Moors Railway for their assistance in the production of these models.

COMET MODELS components required to complete this carriage are:

Underframe	UB1	Bogies	BB2
Underframe castings	UCB1	End castings	ECB1
Ends	EB3	Roof castings	RC3
Interior	INT4	Roof	C10

Modelling Notes

Modifications to underframe UB1

Assemble the underframe as in the instructions to step 5. Reduce the vertical upstands by 2mm at both ends to ensure an easy fit to the assembled bodyshell. The portion of the floor pan which overhangs the solebar between the end and the vertical upstand should be filed back flush with the face of the solebar. Fold down the angle trusses from the floor and remove the lugs for the brake cross shafts. The V hangers in the underframe etch should be discarded and replaced with parts J from the underframe detail etch in the coach sides pack. Fit the V hangers as shown in the diagram overleaf with the brake cross shaft butted up to the truss bars.

Additional underframe components

Note that not all the components are used on every coach type, and those required are shown in the diagrams overleaf. Depending on the history of the coach concerned they could carry either the four or the five element blower box (parts A,B,C,D). One format is shown, and you should rely on photographs for strict accuracy. This also applies to the propane storage boxes (part G).

Fit all the etched components, including additional parts, before fitting the cast cross trusses. Next fit the blower box fan motor and ducting with its overlay (part A). Then fit the battery boxes, dynamo, vacuum cylinders and the pre-assembled trunking. The vacuum release valves should be fitted last.

The ends are identical except that the train alarm gear is fitted only at the end shown on the roof plan

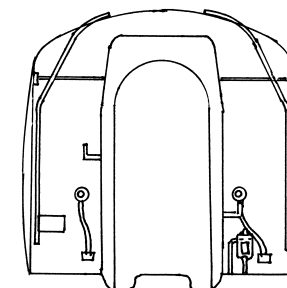

Train alarm gear this end

Mk1 Pullman Bar Second Car

Ridge dome vents

End grab rails

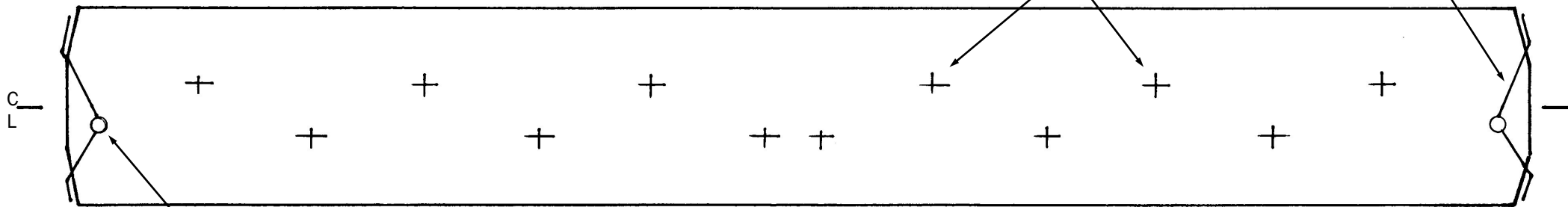

Tank filler

ROOF AND INTERIOR PLANS VIEWED FROM ABOVE

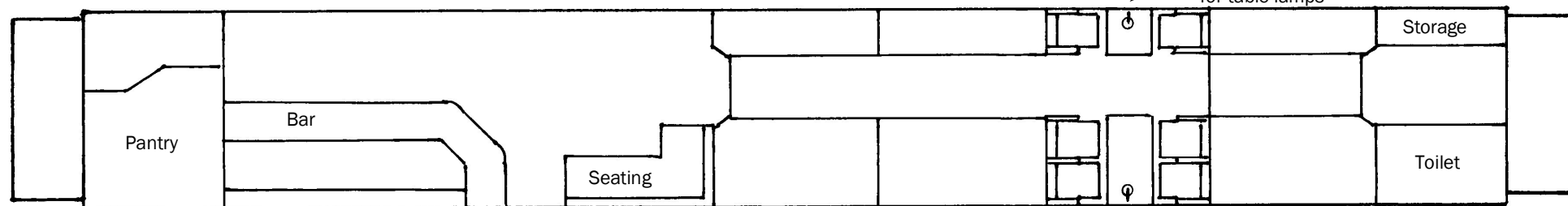

Half window has opaque white glass

UNDERFRAME VIEWED FROM BELOW

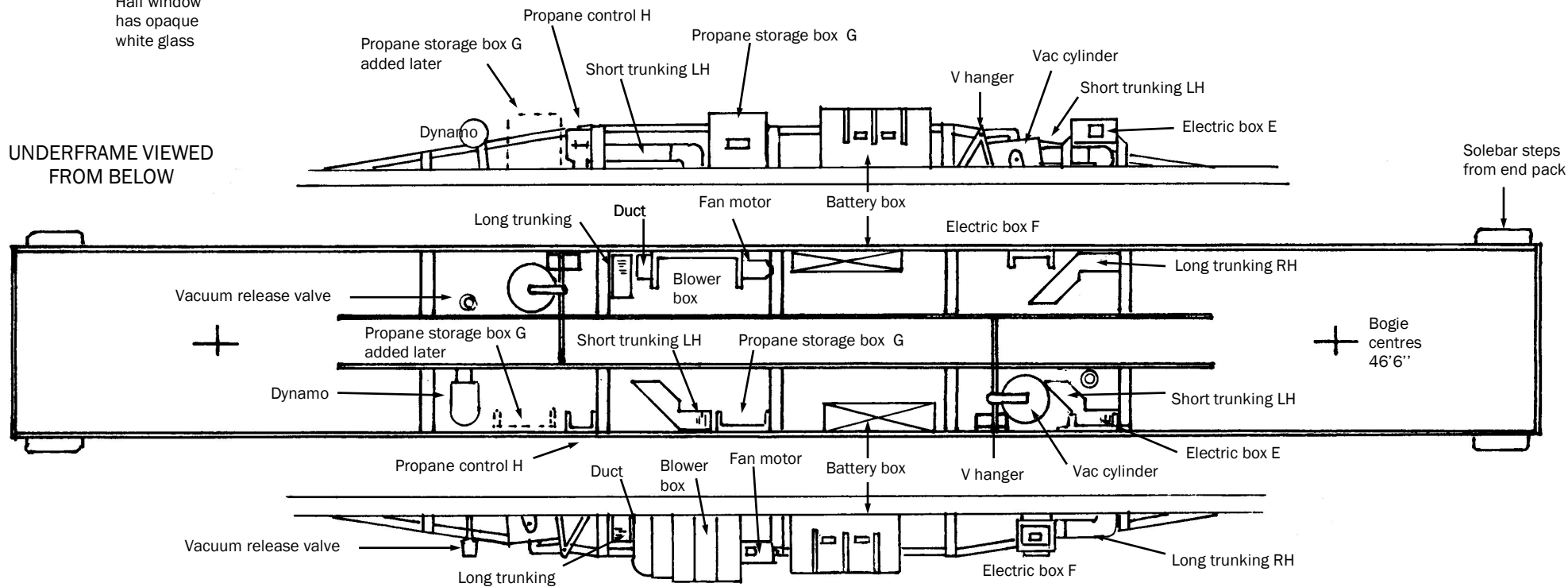

BR Mk1 Pullman underframe equipment

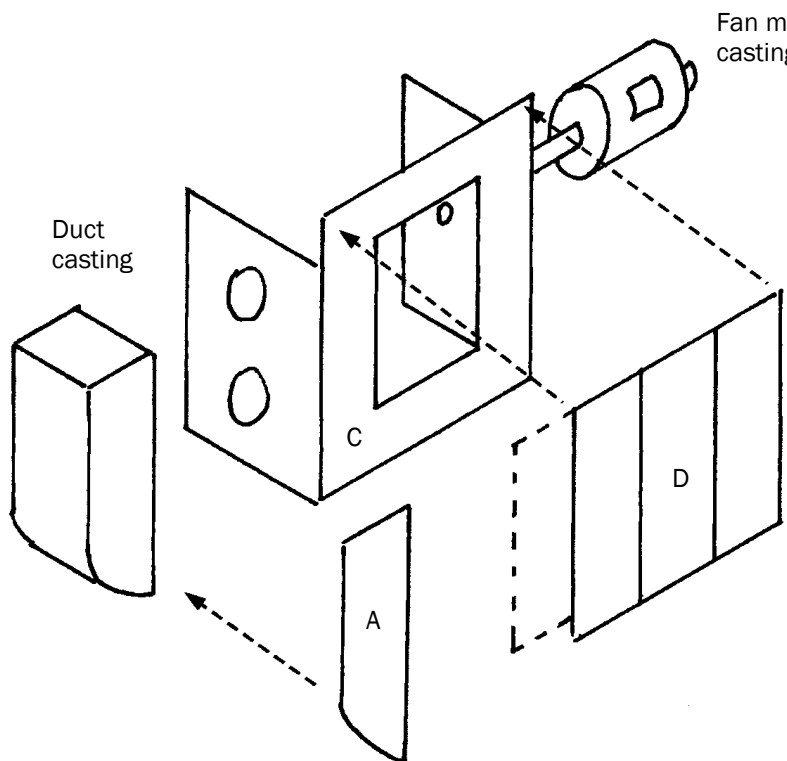

Assembly of 4 element blower box

- 1 Remove dotted section from overlay D.
- 2 Fold up blower box backing C as shown then attach overlay.
- 3 Fit assembly to underframe.
- 4 Attach duct overlay A to duct casting then fit to blower box.
- 5 Fit fan motor casting to blower box.

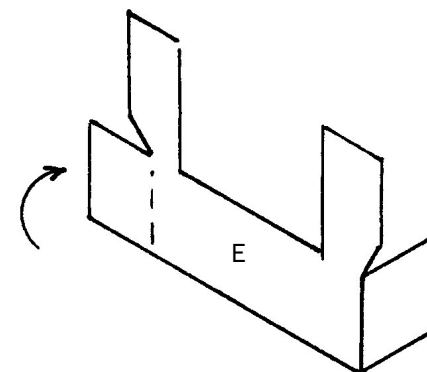

Fold up electrical control box as shown and attach to underframe.

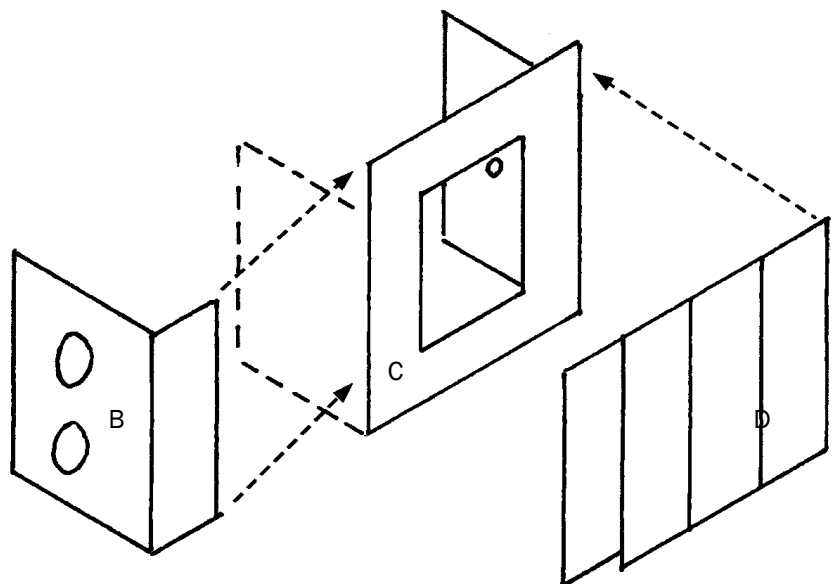

Assembly of 5 element blower box

- 1 Remove dotted section from overlay blower box backing C.
- 2 Attach overlay D to backing.
- 3 Fold backing extension B as shown and attach it alongside the backing against the overlay.
- 4 Fit assembly to underframe and fit duct assembly and fan motor.

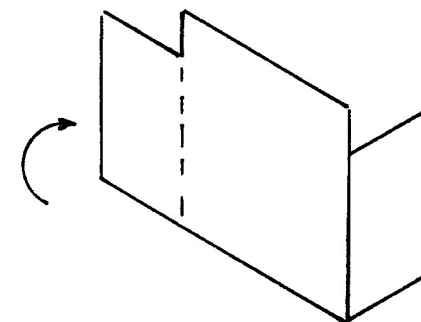

Electrical box F
Propane storage boxes G
Propane control box H

Fold up as shown and attach to underframe.

BR Mk1 Pullman underframe equipment

Up to coach

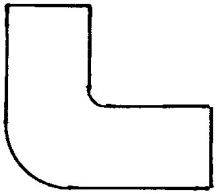

Long trunking side view

Up to coach

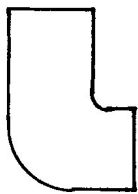

Short trunking side view



Angle trunking top view

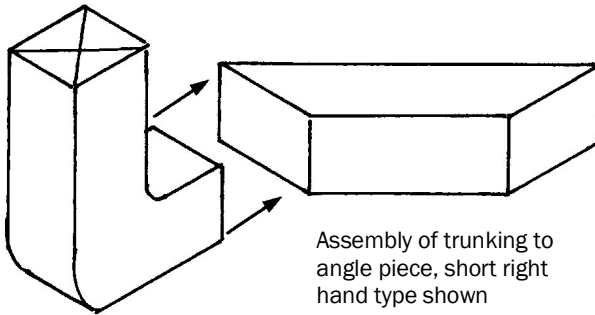

Assembly of trunking to angle piece, short right hand type shown

Short or long trunking

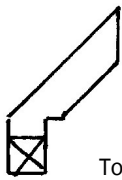

Right hand

Top views of short trunking assembly

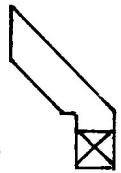

Left hand

Top view of short trunking with extension



Make this piece from angle trunking with angles removed

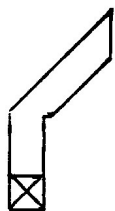

Right hand

Top views of long trunking assembly



Left hand

Suggested method for table lamps

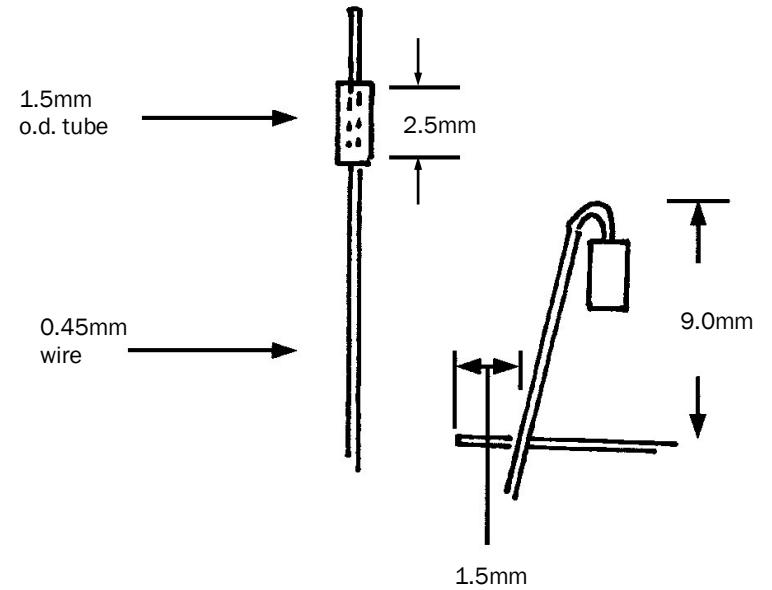

Cut lengths of 1.5mm tube to 2.5mm long.

Solder on to 0.45mm wire, clean up and bend to shape shown.

Drill tables before assembly.

Solder lamp stem to underside.

TIP If the tube is threaded onto the wire and cut by rolling with a sharp knife the cut length will not fly off into the wide blue yonder.