

W72 COLLETT GWR CENTENARY CORRIDOR BRAKE THIRD (BTK)

(Left Hand Van)

Diagram D120

2 built 1935 (1938 as modelled); withdrawn 1962-1963; neither preserved 60'

These etched sides can be built into a complete coach using products from our range as supplied in our full kits. Please refer to the panel opposite. Should you prefer they can also be used to overlay the Hornby (ex Airfix) Centenary coaches, or as a basis for a scratchbuilt coach.

The Centenary coaches were built to commemorate the 100th anniversary of the GWR in 1935. They were luxurious vehicles built to the maximum width of the loading gauge and were the first GWR coaches to feature large windows in the compartments. As a consequence entry was at the ends of the coaches only and due to gauge restrictions the doors were incorporated in an angled inset. The intermediate doors on the brake ended and catering vehicles were also inset. Initially the windows were of the wind down "Beclawat" type but these were replaced in 1938 with the more conventional 4 element sliding vents.

The standard set was of 10 coaches increased to 13 maximum when required. The formation used initially on the *Cornish Riviera Express* (later *Limited*) was, from the tender:-

BTK(LH van)/TK/TK/RTO/RF/CK/BTK(RH van)/TK/BCK/BCK

The maximum formation added a CK, BTK(RH van) and BCK. The vehicles behind the inner BTK were dropped off at intermediate destinations. The set formations lasted into the war years.

In 1947 the coaches were renovated internally and were subsequently seen on the Weston-super-Mare-Paddington trains and then cascaded to lesser workings. The dining pairs worked Paddington-Shrewsbury in the 1950s and in 1961 were on Weston-super-Mare, Wolverhampton and Plymouth trains.

Running numbers

4577/8

Livery

These coaches were painted chocolate and cream, with white roofs. There was a brown strip at the eaves approx. 4" deep with a black line at the boundary. Droplights were painted 'mahogany' - a sort of brick red. Letters and numerals were gold shaded black. Numbers were placed at both ends in the waist panel, which was the 'double lined' variant. Initially on coaches with this type of waist panel thirds were not marked, only firsts, but with the introduction of stock such as this coach having end doors only it became necessary to reintroduce the 'third' to avoid confusion, particularly with composites. GWR was denoted by the 'shirt button' monogram.

The final GWR style appeared from 1943 onwards. The cream panel extended from 7" below the cantrail down to 1½" below the windows. Double lining was applied, the lower waist line being 7" below the upper one. Lining was black and gold, and numbers were in the lining panel at both ends. Roofs were painted grey. The monogram was replaced with the new Coat of Arms in the centre of the panel flanked by the words 'Great' and 'Western'. This was later extended to all coaches built since 1936 which had the double lined waist style. Thus at nationalisation no standard pattern of painting and lining had been achieved.

From 1949 they received BR livery of carmine and cream with gold and black lining. The cream panel was the full height of the windows plus an inch top and bottom. The black line was against the cream. From 1956 they were painted maroon lined gold/black/gold at the waist and black/gold above the windows.

Further information

GWR Coaches 1890-1954
GWR Coaches Vols I & II
GWR Coaches Appendix II
Great Western Way
British Railways Pre-Nationalisation Coaching Stock Vol. 1

Harris David & Charles
J H Russell O.P.C.
J H Russell O.P.C.
J N Slinn H.M.R.S
H Longworth O.P.C.

COMET MODELS components required to complete this carriage are:

Underframe	UW4	Bogies	BW5
Underframe castings	UCW1	End castings	ECW2
Ends	EW9	Roof castings	RC5
Roof	C10	Interior	INT1

Scrap views showing additional detailing of sides and ends
(not all details may apply to this diagram)

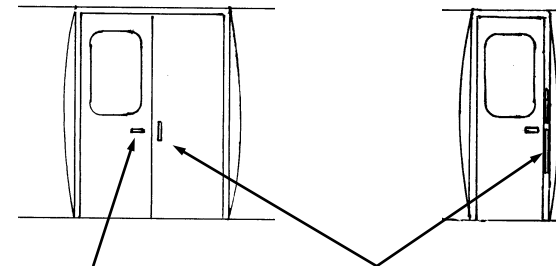

'T' door handles are supplied in complete kits and are available in product C6

Make grab handles from 0.45mm wire

Door hinges, gangway suspension brackets, train alarm gear ears, gangway end covers and solebar ascending steps are available in product C26

Note that the train alarm gear, steps and filler pipes were present only at the end shown on the roof plan overleaf. The other end was plain.

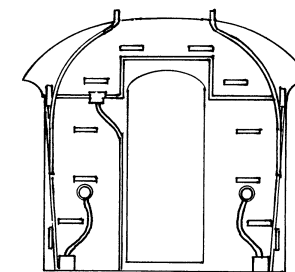

Make grab handles from 0.45mm wire

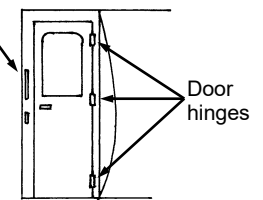

Door hinges

D120

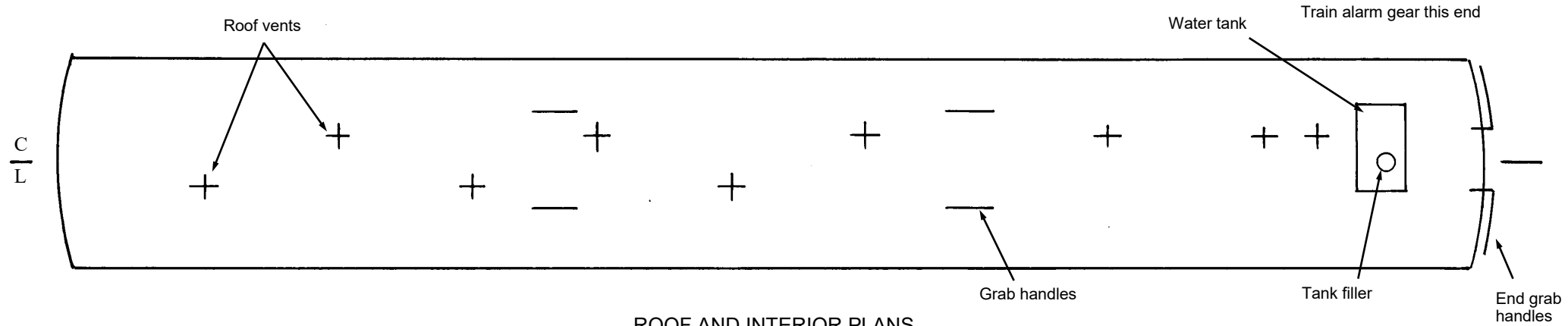

ROOF AND INTERIOR PLANS VIEWED FROM ABOVE

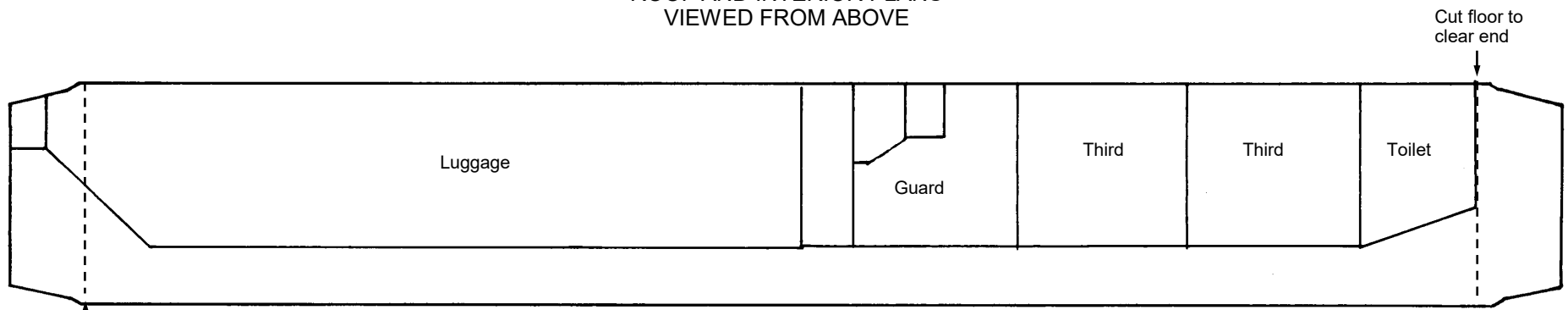

UNDERFRAME VIEWED FROM BELOW

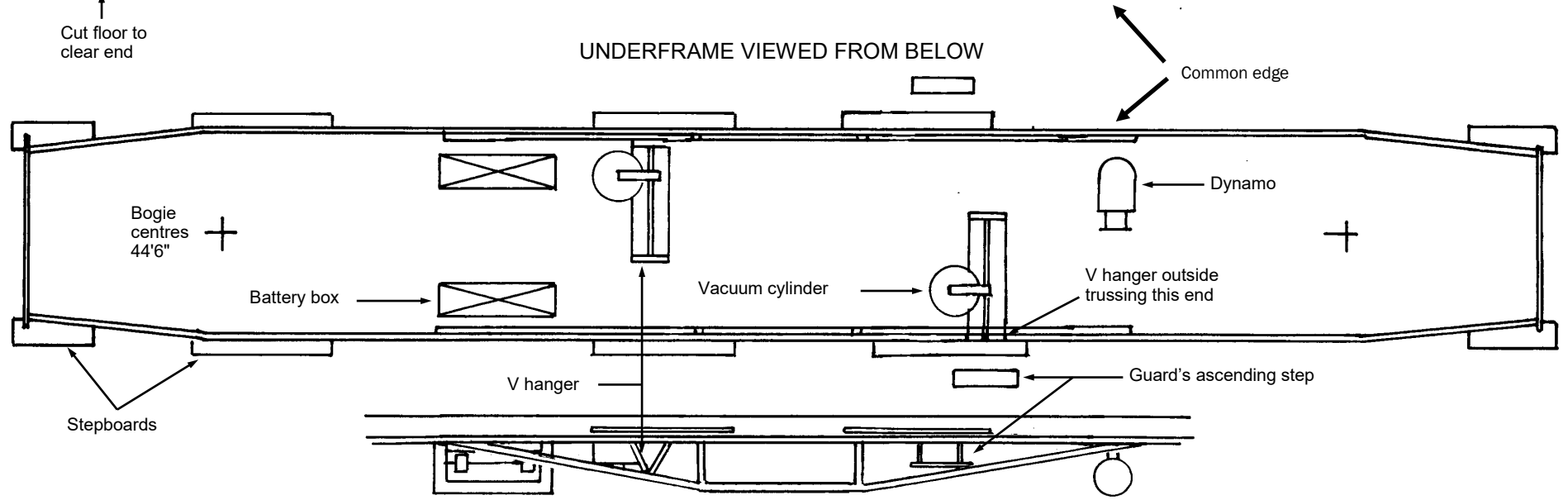

Additional assembly instructions for GWR Centenary Stock and Super Saloons

These etched sides can be built into a complete coach using products from our range as supplied in our full kits. Should you prefer they can also be used to overlay the Hornby (ex-Airfix) corridor composite or brake third, or as a basis for a scratchbuilt coach. Note that the sides for the corridor brake thirds W72 or W73, brake composite W74 and restaurant first W75 all feature inset sections, so that you must first complete steps 3-5 below before proceeding to overlay, and also make any necessary modifications to the chosen donor coach. For all types, you will also need to remove the gutter strip along the top of the side. This is best done by scoring the half etched line with a sharp craft knife until the gutter strip can be fatigued off and the top edge filed smooth.

Please note that when built these coaches had wind down "Beclawat" windows which did not have any integral ventilators. Remove the etched sliding vent bars if you wish to depict your coach in this early condition.

If you are using these sides as part of a complete kit the following construction sequence is suggested.

- 1 Clean off the remains of the holding tabs along the top of the gutter overlay strip but do not detach it from the coach side.
- 2 Refer to sketch 1. Fold the gutter overlay strip 180° with the half etch to the outside of the fold, align it along the half etched line at the top of the side and solder it in place along the top edge. Clean off the remains of the tabs along the top of the gutter and any tabs elsewhere on the coach side.

If you are building a restaurant third, corridor third or composite coach proceed to step 6, otherwise

- 3 Fit droplight frames to any doors in the flat inset sections of the coach sides.
- 4 Refer to sketch 2. Drill out to 0.5mm the locating holes in the indexing strips at the bottom of the inset sections and the strips below the voids in the coach sides.
- 5 Hold each inset section behind the void in the coach side and pass short lengths of 0.45mm wire through the indexing holes in both parts to ensure correct alignment. Solder the inset section to the inside face of the side at all four corners, then fatigue off both the bottom strips at the half etched lines and file smooth. Repeat until all inset sections are fixed in place.
- 6 Refer to sketch 3. Assemble the end etches in accordance with their instructions, and prepare the underframe Code UW4 as far as step 2.
- 7 If the coach does not have identical ends check that you have the handing correct. Bolt the assembled ends to the underframe, ensuring that they are a close fit on length and a true 90° to the floor.
- 8 Rest the side down onto the top of the ends and adjust the angle of the curved fillet on the end until it is just inside the end of the sides. Solder the extension of the gutter strip to the false roof of the end so that the bottom of the gutter strip is aligned with the underside of the false roof and solder in place as shown in sketch 4. Tack solder the top and bottom of the curved fillet to the coach side as shown in sketch 6 but do not solder it to the underframe. Repeat for the other end and for the other side.

- 9 Solder the three stretchers across the top of the bodyshell at convenient positions, ideally above a window. Try to set these at or slightly below the level of the false roof of the ends.
- 10 Unbolt the bodyshell from the underframe and complete the soldered joints at the sides and ends.
- 11 Refer to sketch 5. Cut the roof section to the same length as the bodyshell and remove the bottom rebate where it crosses the false roof on the ends and the three body stretchers. Note that the roof fits inside the gutters.
- 12 Refer to the roof, end and floor plans. If the coach does not have identical ends ensure the correct casting is chosen for each end. Attach both cast ends using adhesive or by soldering through the holes in the etched end.
- 13 Adjust the length of the roof section so that it fits closely inside the two end castings, and slightly below the level of the top curve of the castings. Mark and drill the positions for the roof detail as shown in the plans in the sides pack. Fix in place with epoxy adhesive and when set file and sand down the end castings to achieve a flush joint. Fit roof detail parts.
- 14 Refer to sketch 6. Fill in the fillets at the sides of the end insets and at the edges of the flat inset sections. Use as a guide the etched lines beyond the door part lines in the intermediate sections and the fold point of the fillets on the end sections.
- 15 File back the gutter extension to leave a slight projection beyond the end of the coach. Fit the gangway bellows only as the base is not required on bow ends. Fit the jumper cables and make and fit the end grab handles from 0.45mm wire. Door handles, and grab handles on the coach sides are best added after painting, lining and glazing the coach.

The coach may be further detailed using our coach detailing pack Code C26. Note, however, that some of the components offered in this product are best fitted before the coach is painted.

SKETCH 1

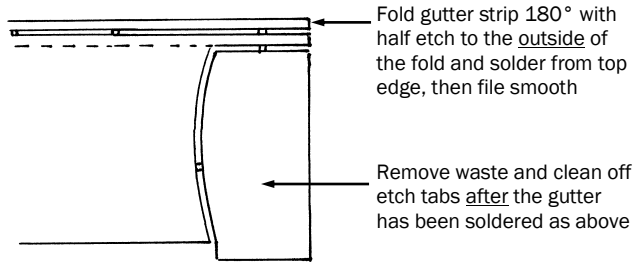

SKETCH 2

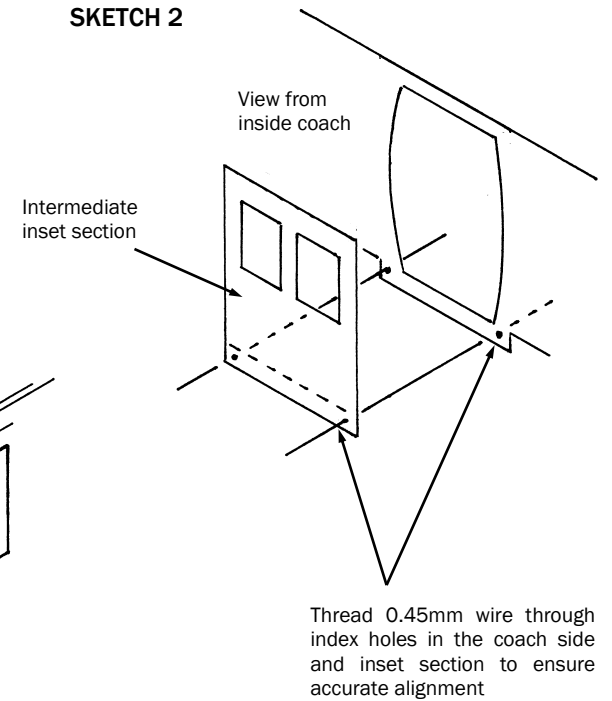

SKETCH 3

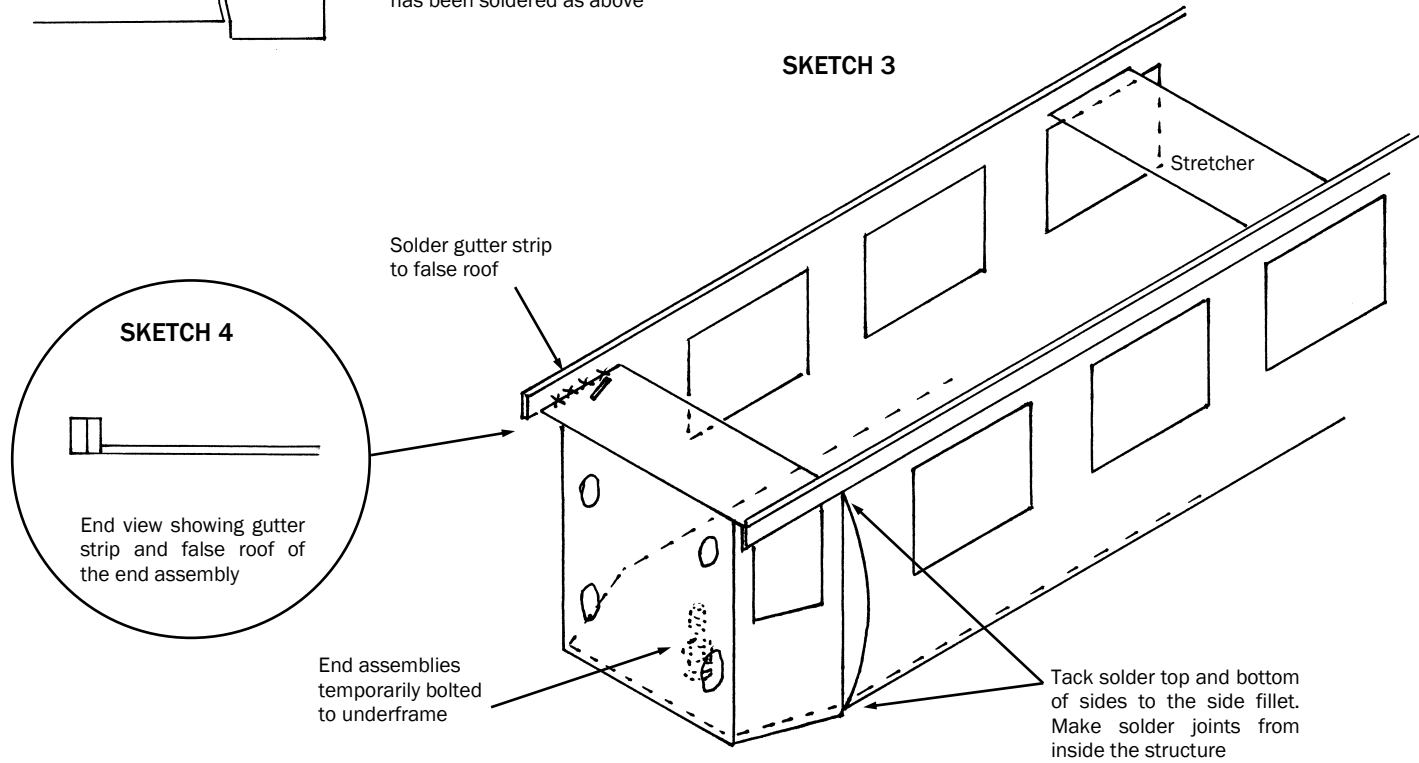

SKETCH 4

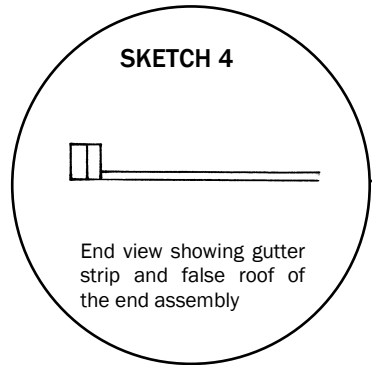

SKETCH 6

Section through inset end

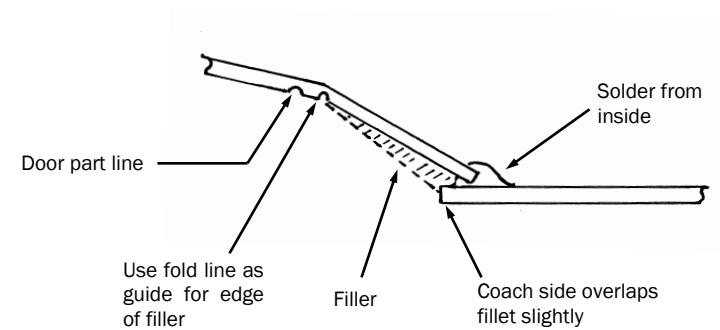

SKETCH 5

